

PROGRAMMABLE I/f CONVERTER



- Input for TC/RTD, lin. resistance mV or mA and V
- Frequency output NPN, PNP, TTL
- Programmable from PC
- 3.75 kVAC galvanic isolation
- AC/DC-supplied
- DIN rail mounting



General:

The PRecon 5222 converter is configured to the present application by means of a standard PC using the configuration kit Loop Link. The converter may be configured prior to installation or directly in the process. The PRecon 5222 may be ordered configured from factory according to your specifications, please see the options index.

Input types for 5222 A1:

RTD input for Pt100/Ni100 in temperature ranges acc. to IEC 751 and DIN 43760. By way of Loop Link, the cable resistance can be measured and compensated on a 2-wire connection. Automatic cable compensation on a 3- or 4-wire connection.

Thermocouple input (TC) for standard thermocouples in temperature ranges acc. to IEC 584, DIN 43710, or ASTM E988-90.

Internal CJC with Pt100 sensor in the connector (optional - type 5910 and 5913), external CJC with Pt100/Ni100 on a 2-wire connection, or fixed CJC (thermostat box).

Resistance input for ohmic resistance measurement, max. range 5000 Ω . Automatic cable compensation on a 3- or 4-wire connection.

mV input for DC voltage signals.

Sensor and cable errors:

At sensor and / or cable errors for TC, RTD, and resistance inputs, the output can be programmed to adopt a programmable value.

Input types for 5222 A2:

Current input for signals of max. 100 mADC. The input is protected by a PTC resistor.

Voltage input for signals of max. 250 VDC.

Auxiliary supplies:

Loop supply 16..28 VDC / 20 mA for supply of a loop-powered transmitter.

Reference voltage 2.5 VDC / 15 mA as reference for 3-wire potentiometer.

Outputs:

The PNP, NPN and TTL outputs are galvanically separated from supply and input.

The outputs are current-limited by way of PTC resistors.

It is possible to reverse the output in relation to input.

Pulse time is programmable.

From PReset a "LOW CUT OFF" value can be selected, which means that the output is fixed to 0 Hz, when the input is below the "LOW CUT OFF" value.

Response time is programmable.

NPN and PNP outputs for external relay, electromechanical counter, PLC input, or equivalent load.

Active output is established by connecting the NPN to the PNP output (jumper pins 13-14).

The PNP output can emit pulses of 20 ms to electromechanical counters.

Linearisation:

The output signal is linearised according to the selected sensor type, but customer-specific linearisations are also possible.

Set-up:

Loop Link contains PReset software, adapter box, cable, etc. The adapter has galvanic isolation to protect the PC.

Communication between PRecon 5222 and Loop Link is fully two-way, meaning that the set-up parameters and series / TAG numbers can be retrieved from any PRecon for control and reconfiguration.

Electrical specifications:

Specifications range:
-20°C to +60°C

Common specifications:

Supply voltage
Version 5222---A- 19.2...78 VDC
21.6...52.8 VAC
Version 5222---B- 80...300 VDC
72...253 VAC
Frequency..... 50...60 Hz
Current consumption..... ≤ 2.6 W
Fuse..... 400 mA SB / 250 VAC
Isolation, test / operation..... 3.75 kVAC / 250 VAC
Communications interface Loop Link
Response time (programmable):
Version 5222-1-- (temp. vers.) 350 ms...60 s
Version 5222-2-- (mA / V vers.)..... 200 ms...60 s
Updating time:
Version 5222-1-- (temp. vers.) 100 ms
Version 5222-1-- (mA / V vers.)..... 60 ms
Signal dynamics, input 20 bit
Calibration temperature..... 20...28°C
Temperature coefficient..... < ±0.01% of span / °C
Linearity error < 0.1% of span
Effect of supply voltage change..... < 0.005% of span / V

Auxiliary voltages type 5222-2:
Reference voltage 2.5 VDC ±0.5% / 15 mA
Loop supply..... 28 VDC / 0 mA
16 VDC / 20 mA

EMC immunity influence < ±0.5%

Wire size (max.) 1 x 2.5 mm² stranded wire
Screw terminal torque 0.5 Nm
Humidity < 95% RH (non-cond.)
Dimensions (HxWxD)..... 109 x 23.5 x 130 mm
DIN rail type..... DIN 46277
Tightness (cabinet / terminals) IP50 / IP20
Weight 250 g

Electrical specifications - INPUT type 5222-1:

TC input:

Type	Min. temp.	Max. temp.	Min. span	Norm
B	+400°C	+1820°C	200°C	IEC584
E	-100°C	+1000°C	50°C	IEC584
J	-100°C	+1200°C	50°C	IEC584
K	-180°C	+1372°C	50°C	IEC584
L	-100°C	+900°C	50°C	DIN43710
N	-180°C	+1300°C	100°C	IEC584
R	-50°C	+1760°C	200°C	IEC584
S	-50°C	+1760°C	200°C	IEC584
T	-200°C	+400°C	50°C	IEC584
U	-200°C	+600°C	75°C	DIN43710
W3	0°C	+2300°C	200°C	ASTM E988-90
W5	0°C	+2300°C	200°C	ASTM E988-90

Max. offset..... 50% of selec. max. value
Sensor current Nom. 100 nA
Basic accuracy:
Type E,J,K,L,N,T,U < ±1°C
Type B,R,S,W3,W5 < ±2°C
Compensation accuracy (CJC) < ±1°C
Temperature coefficient:
Type E,J,K,L,N,T,U
span < 500°C ±0.05°C / °Camb.
span > 500°C ±0.01% of span / °Camb.
Type B,R,S,W3,W5 0.2°C / °Camb.
Sensor error indication (output)..... Upscale / downscale

mV input:

Measurement range 0...100 mV
Min. measurement range..... 5 mV
Max. offset..... 50% of selec. max. value
Input resistance Nom. 10 MΩ

RTD input:

RTD type	Min. value	Max. value	Min. span.
Pt100	-200°C	+850°C	25°C
Ni100	-60°C	+250°C	25°C
Lin. R	0 Ω	5000 Ω	30 Ω

Max. offset..... 50% of selec. max. value
Cable resistance per wire (max.) 10 Ω
Sensor current..... Nom. 0.2 mA
Basic accuracy < ±0.2°C
Temperature coefficient:
span < 100°C ±0.01°C/°Camb.
span > 100°C ±0.01% of span/°Camb.
Effect of sensor cable resistance
(3- / 4-wire) < 0.002 Ω/Ω
Sensor error indication (output)..... Upscale / downscale

Linear resistance input:

Measurement range 0...5000 Ω
Min. measurement range (span)..... 30 Ω
Max. offset..... 50% of selec. max. value
Max. cable resistance per wire..... 10 Ω
Sensor current..... Nom. 0.2 mA
Effect of sensor cable resistance
(3- / 4-wire) < 0.002 Ω/Ω
Sensor error indication (output)..... Upscale / downscale

Electrical specifications - INPUT type 5222-2

Voltage input:

Measurement range 0...250 VDC
Min. measurement range (span)..... 50 mVDC
Max. offset..... 50% of selec. max. value
Input resistance ≤ 2.5 VDC Nom. 10 MΩ
> 2.5 VDC..... Nom. 5 MΩ

Current input:

Measurement range 0...100 mA
Min. measurement range (span)..... 4 mA
Max. offset..... 50% of selec. max. value
Input resistance:
Supplied unit Nom. 10 Ω + PTC 10 Ω
Non-supplied unit..... RSHUNT = ∞, VDROPP < 6 V

Electrical specifications - OUTPUTS:

Frequency range 0.00005...25000 Hz
Min. frequency (span)..... 0.00005 Hz
Duty cycle (0...25000 Hz) 50%
or
Program. pulse width (f < 500 Hz)..... 1...1000 ms
Max. 90% duty cycle

PNP output:

I_{out} max. 30 mA
I_{out} max. peak 170 mA
V_{out} min./max. 22 / 26 V
C_{out} 10 nF
R_{out} typ. 25 Ω
Electromechanical counter..... 24 V / 135 mA / 20 ms

NPN output:

I_{sink} max. 150 mA
I_{sink} max. peak 300 mA
Max. input..... 55 V
C_{out} 10 nF
R_{out} typ. 10 Ω

TTL output:

I_{sink}/source min. 15 mA
I_{sink}/source peak 100 mA
V_{out}..... 5 V ±5%
C_{out} 10 nF
R_{out} typ. 55 Ω

Observed authority requirements: Standard:

EMC 2004/108/EC
Emission and immunity EN 61326
LVD 73/23/EEC..... EN 61010-1
PELV/SELV..... IEC 364-4-41
and EN 60742

Of span = Of the presently selected range

Options index for the 5222 programmable I/f converter:
(Use this as a checklist when ordering configured units)

INPUT OPTION: 1 TC/RTD/Linear resistance/mV				INPUT OPTION: 2 mA/Voltage		
RTD type: Pt100 (DIN/IEC) Ni100 Specify type : ____ Specify range °C: ____	Thermocouple type: Pt30%Rh-Pt6%Rh: type B NiCr-CuNi : type E Fe-CuNi : type J NiCr-Ni : type K Fe-CuNi : type L NiCrSi-NiSi : type N Pt13%Rh-Pt : type R Pt10%Rh-Pt : type S Cu-CuNi : type T Cu-CuNi : type U W3%Re/W25%Re : type W3 W5%Re/W26%Re : type W5 Specify type : ____ Specify range °C : ____	Linear resistance range: (30 Ω ≤ range ≤ 5000 Ω) Specify range Ω : ____	mV input range: 5 mV ≤ range ≤ 100 mV Specify range mV : ____	mA input range: 4 mA ≤ range ≤ 100 mA Specify range mA : ____	Voltage input range: 50 mV ≤ range ≤ 250 VDC Specify range mV/V: ____	
RTD options: 2-wire, no compens. 2-wire, fixed line res. 3-wire compensation 4-wire compensation Specify wire : ____	TC options: Internal CJC (Pt100) : External CJC (Pt100): External CJC (Ni100): Fixed external CJC : Specify CJC : ____	Resistance options: 2-wire, no compensation: 2-wire, fixed line resistance 3-wire compensation: 4-wire compensation: Specify wire : ____	mA options: Loop supply: 16...28 VDC Specify loop supply or 2.5 V ref. : ____			Voltage options: Vref.: 2.5 VDC (e.g. potentiometer input as voltage divider)
Linearisation No linearisation: Customer linearisation (specify):						
Response time: 350/200 ms ≤ response time ≤ 60 s (min. response time depending on input type)						

OUTPUT

Frequency output: 0 Hz < Range < 25000 Hz Output frequency 0% (specify) : ____ Output frequency 100% (specify) : ____ LOW CUT OFF frequency (specify) : ____ Pulse time (f < 500 Hz) (specify) : ____

5222 connection to Loop Link:

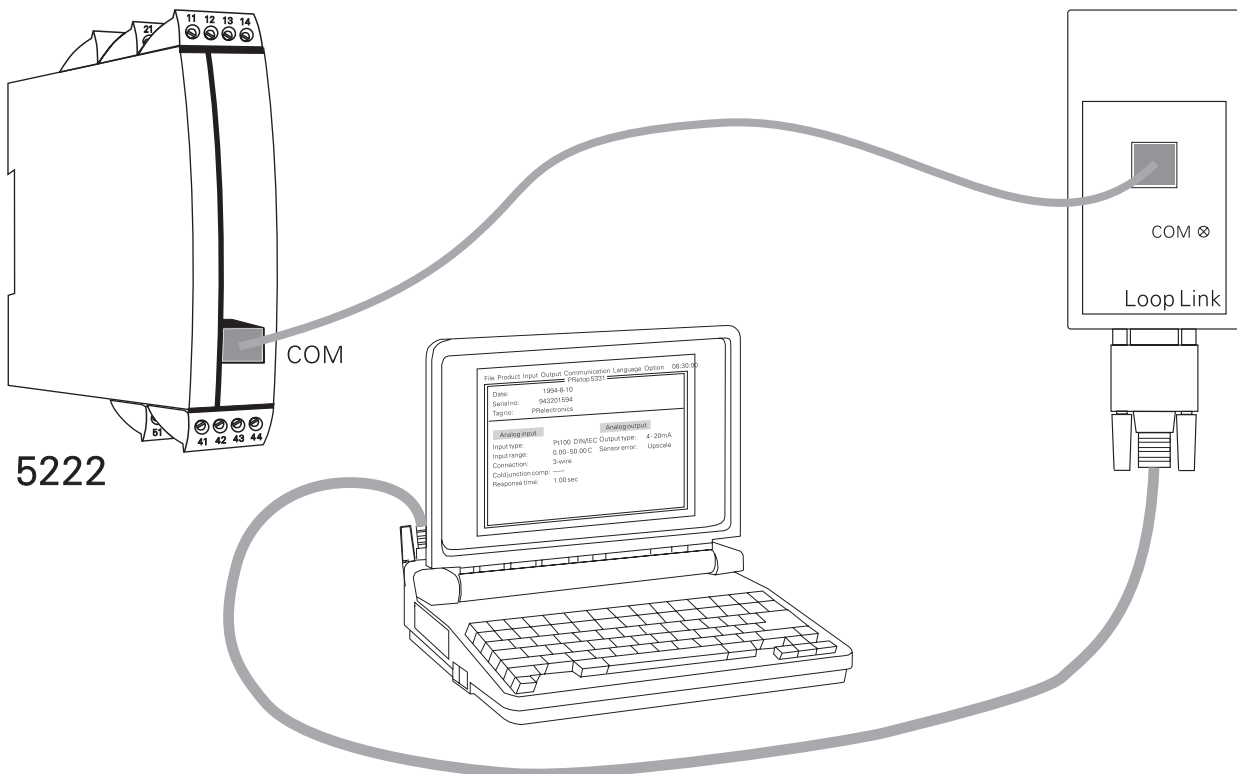

Order: 5222

Type	Version	Input	Supply
5222	Standard : A	RTD / TC / mV / R : 1	24...65 VDC / 24...48 VAC : A
		mA / V / mV : 2	100...250 VDC / 80...230 VAC : B

Note! For TC inputs with internal CJC, remember to order the CJC connector type 5910.

Block diagrams:

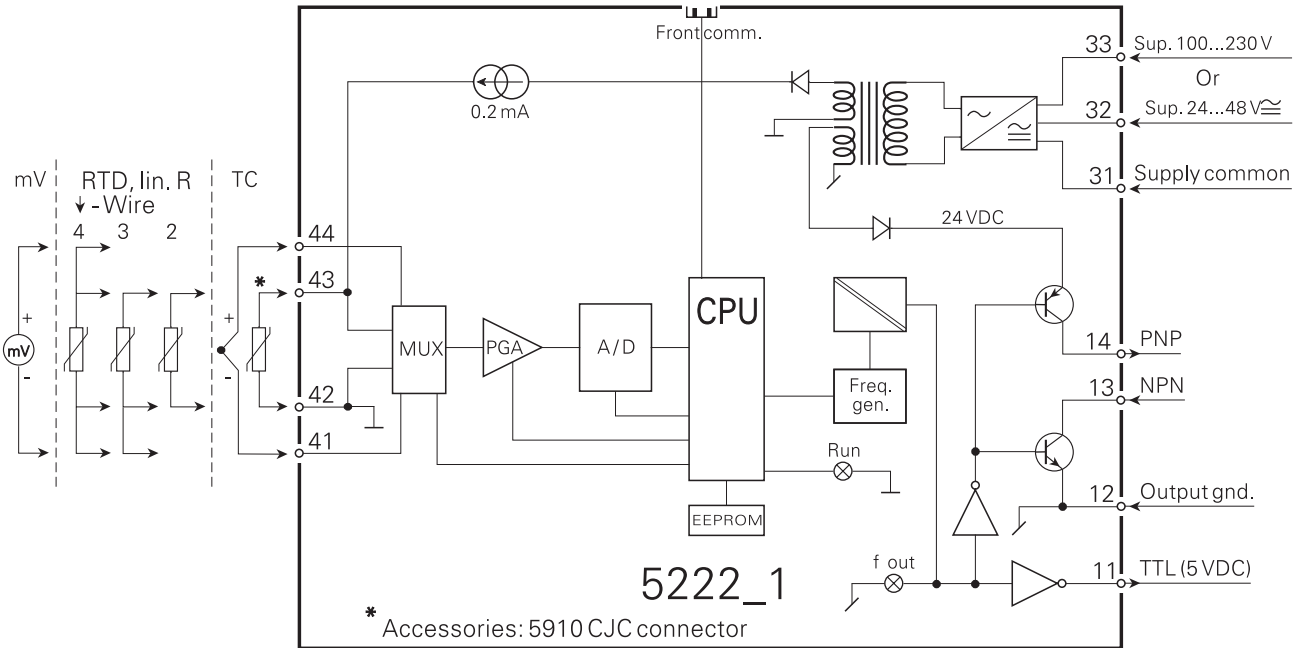

Input: 2

